

GLOBE 592A BRONZE

200 lb. SWP @ 550°F-400 lb. WOG† @ 150°F • Heavy Duty Service
Special Hardened S. S. Seat Ring and Disc • Union Bonnet
Gland Packed • Threaded Ends

- This valve has flat seat shutoff with plug type disc for throttling action and replaceable seat and disc.

SPECIFICATIONS

592A	Conforms to: MSS SP-80, Type 3, Class 200, Threaded Ends.
------	--

MATERIAL LIST

NO.	PART	MATERIAL	SPECIFICATION
1	Body	Bronze	ASTM B 61
2	Bonnet	Bronze	ASTM B 61
3	Bonnet Nut	Bronze	ASTM B 61
4	Stuff Nut	Bronze	ASTM B 62
5	Stem	Bronze	ASTM B 61
6 ¹	Disc Ring	Bronze	ASTM B 62
7	Seat Ring	St. Steel	ASTM A 276, TY. 420
8	Disc	St. Steel	ASTM A 276, TY. 420
9	Gland	Brass	ASTM B 124 C37700
10	Wheel Nut	Brass	ASTM B 16
11	Handwheel	Mall. Iron	Commercial
12	Packing	Graphite	
13	Name Plate	Sh. Alum.	Commercial

¹ Not shown - used on 1 1/4" and larger valves only.

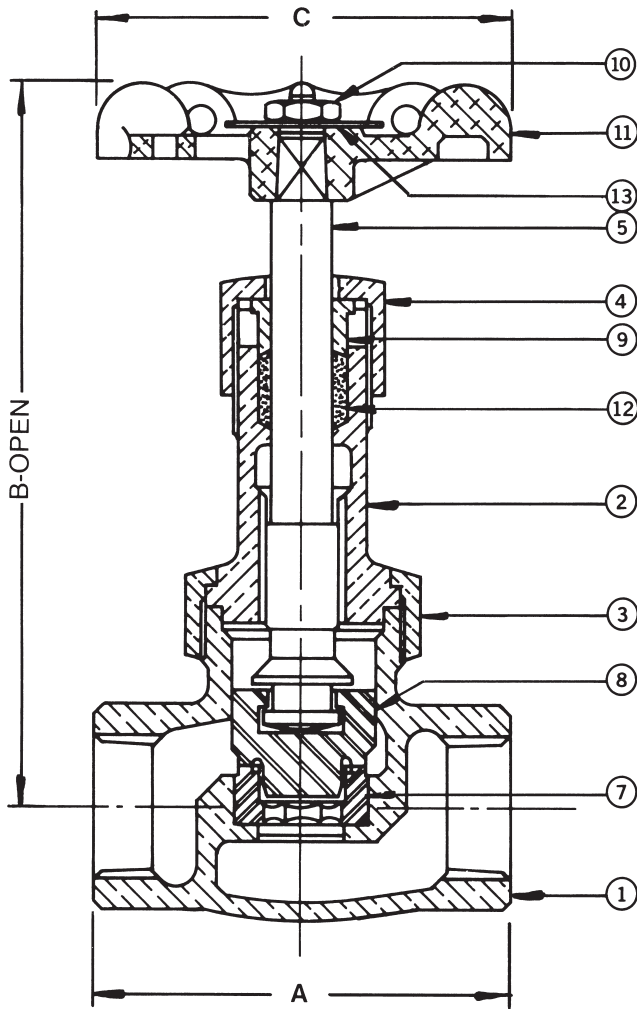

DIMENSIONS - INCHES / MILLIMETERS

Units	Size	A	B	C	C _v
Inches	1/4	2.13	4.38	2.00	1.16
mm	6.4	54.0	111.1	50.8	
Inches	3/8	2.38	4.44	2.00	2.21
mm	9.5	60.3	112.7	50.8	
Inches	1/2	2.50	4.50	2.50	3.64
mm	12.7	63.5	114.3	63.5	
Inches	3/4	2.94	5.13	2.75	6.65
mm	19.1	74.6	130.2	69.9	
Inches	1	3.38	5.25	3.25	11.10
mm	25.4	85.7	133.4	82.6	
Inches	1 1/4	3.88	6.19	3.75	20.00
mm	31.8	98.4	157.2	95.3	
Inches	1 1/2	4.50	7.25	4.25	28.00
mm	38.1	114.3	184.2	108.0	
Inches	2	4.88	8.19	4.75	48.00
mm	50.8	123.8	208.0	120.7	

† Non-Shock

Rev. 6

INNOVATION IN EVERY VALVE



MILWAUKEE VALVE

www.milwaukeevalve.com

The information presented on this sheet is correct at the time of publication. Milwaukee Valve reserves the right to change design, and/or material specifications without notice. For the Installation, Operation and Maintenance Manual (IOM) see the engineering section on our website. For the most current information access www.milwaukeevalve.com